

hotrod

Cartridge Heaters



hotrod

Cartridge Heaters

Components and Systems

Heating elements, thermal sensors and process control – hotset is your partner for the realization of intelligent product and service solutions in the field of industrial heat technology. Based on our international presence and our own production sites, we operate as a component supplier and development service provider for customers in all industries.

We supply you with components for your series production, we implement complex system solutions for you or we take over entire value chains: your requirements, your goals and your wishes always form the centre of our actions. You benefit from flexible production and logistics structures, an interdisciplinary engineering and over four decades of technology experience.

hotset – components. systems. projects.

Facts

- For heating applications:
 - Packaging machines
 - Extruders
 - Casting machines
 - Hot melt
 - Cutting knives
 - Analytical equipment in laboratories
- Custom options:
 - Power distribution
 - Numerous attachments and protection sleeves
 - Various moisture protection options
- Special Features:
 - High quality stainless steel with special alloy properties for improved
 - heat conductivity, thermal expansion and corrosion resistance
 - Standard diameter tolerances to fit H7 bore tolerances
 - The most precise diameter tolerances in the industry: up to -0.02 / -0.04 mm available
 - Certified according to UL and CSA standards on request
 - VDE certification versions
 - Protection class IP67 available on request
 - 24h/48h express manufacture

Application Fields

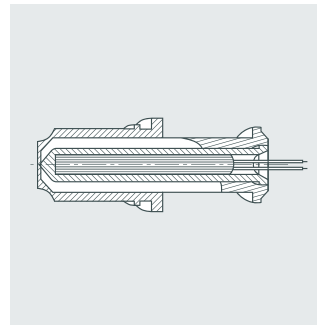

Plastic injection molding
Internal heating of nozzles

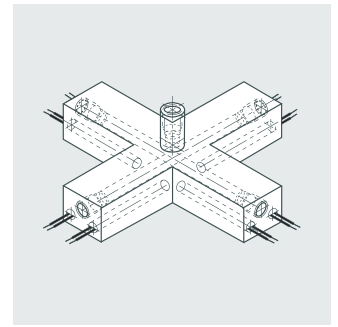

Hot runner systems
Heating of manifolds

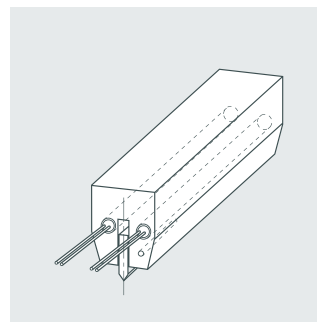

Packaging industry
Heating of sealing bars

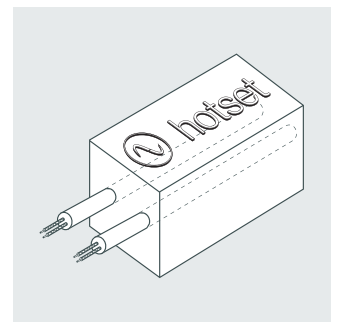

Packaging industry
Heating of hot stamps

Technical Key Features

Sheath material	Stainless steel 1.4541
Heating conductor material	NiCr 8020
Insulator	pure magnesium oxide, high density
Max. sheath temperature	750 °C / 1380 °F (up to 1000 °C / 1832 °F on request)
Max. voltage	480 V, UL max. 300 V
Wattage tolerance*	± 10 %
Insulation resistance*	≥ 5 MΩ at 500 V DC
Leakage current*	≤ 0.5 mA at 253 V AC
Length tolerance	± 1.5 %, min ± 1 mm
Standard diameter tolerance for metric sizes:	-0.02 -0.06 mm
Standard diameter tolerance for imperial sizes:	± 0.79 mil [± 0.02 mm]
Final electrical test	routine test analogous to EN 60335-1 (VDE 0700)

*tested at environmental temperature

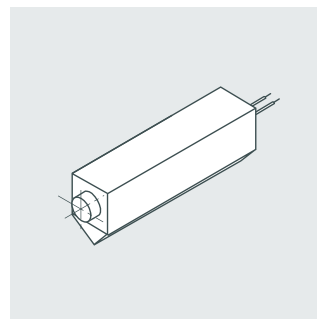

Textile industry
Heating of cutting knives

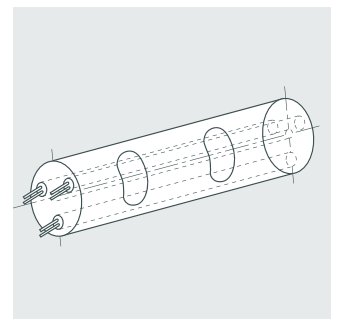

Paper industry
Heating of embossing rollers

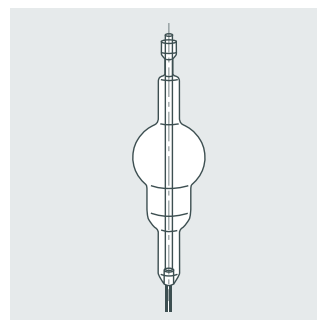

Laboratories
Heating of analytical equipment,
for example, Mass spectrometers

Performance Range

Options

Type	Φ	Φ-Tolerance	max. L [mm/inch]	max. W/cm ²	max. W/inch ²	max. W/cm ² UL recognized	max. Temp [°C/°F]	max. U [V]	Thermocouple	Attachments	Power Distribution	Moisture Protection																																																	
HHP	4 mm	-0.02 mm -0.06 mm	350 / 13.8	30	190	n/a	275/650 527/1202	250	limited	no	yes	limited																																																	
	6.0 mm	-0.02 mm -0.06 mm	1500 / 59	65*	419*	57*	750/ 1380	480	yes	limited		yes	IP67																																																
		± 0.1 mm	3000 / 118	10	65	10				limited																																																			
	6.5 mm	-0.02 mm -0.06 mm	1500 / 59	65*	419*	57*				750/ 1380				480	yes	yes	yes	IP67																																											
		± 0.1 mm	3000 / 118	10	65	10													limited																																										
	8 mm	-0.02 mm -0.06 mm	1500 / 59	65*	419*	57*													750/ 1380	480	yes	yes	yes	IP67																																					
		± 0.1 mm	3000 / 118	10	65	10																			limited																																				
	10 mm	-0.02 mm -0.06 mm	1500 / 59	65*	419*	57*																			750/ 1380	480	yes	yes	yes	IP67																															
		± 0.1 mm	3000 / 118	10	65	10																									limited																														
	12 mm	-0.02 mm -0.06 mm	1500 / 59	65*	419*	57*																									750/ 1380	480	yes	yes	yes	IP67																									
		± 0.1 mm	3000 / 118	10	65	10																															limited																								
	12.5 mm	-0.02 mm -0.06 mm	1500 / 59	65*	419*	57*																															750/ 1380	480	yes	yes	yes	IP67																			
		± 0.1 mm	3000 / 118	10	65	10																																					limited																		
	16 mm	-0.02 mm -0.06 mm	1500 / 59	65*	419*	57*																																					750/ 1380	480	yes	yes	yes	IP67													
		± 0.1 mm	3000 / 118	10	65	10																																											limited												
	20 mm	-0.02 mm -0.06 mm	1500 / 59	65*	419*	57*																																											750/ 1380	480	yes	yes	yes	IP67							
		± 0.1 mm	3000 / 118	10	65	10																																																	limited						
	1/8"	± 1.97 mil	150	30	190																																																		700/1292	250	no	no	yes	limited	
	1/4"	± 0.79 mil	1500 / 59	65*	419*	57*																																																	750/ 1380	480	yes	yes		yes	IP67
		± 3.94 mil	3000 / 118	10	65	10																																																							
3/8"	± 0.79 mil	1500 / 59	65*	419*	57*	750/ 1380					480																																																		
	± 3.94 mil	3000 / 118	10	65	10		limited																																																						
1/2"	± 0.79 mil	1500 / 59	65*	419*	57*		750/ 1380	480	yes			yes	yes																																																
	± 3.94 mil	3000 / 118	10	65	10					limited																																																			
5/8"	± 0.79 mil	1500 / 59	65*	419*	57*					750/ 1380				480	yes	yes	yes	IP67																																											
	± 3.94 mil	3000 / 118	10	65	10														limited																																										
3/4"	± 0.79 mil	1500	65*	419*	57*														750/ 1380	480	yes	yes	yes	IP67																																					
	± 0.394 mil	3000	10	65	10																				limited																																				
LHT	6.5 mm	± 0.1 mm	3000 / 118	10	65																				10	750/ 1380	480	no	limited	no																															
	8 mm	± 0.1 mm	3000 / 118																																																										
	10 mm	± 0.1 mm	3000 / 118																																																										
	12.5 mm	± 0.1 mm	3000 / 118																																																										
	16 mm	± 0.1 mm	3000 / 118																																																										
	20 mm	± 0.1 mm	3000 / 118																																																										
LHT bendable	6.5 mm	± 0.2 mm	3000 / 118	700/ 1292																																																									
LHT bendable	8 mm	± 0.2 mm	3000 / 118																																																										

Formula for calculating the surface load: $W/cm^2 = \frac{\text{Wattage [W]}}{\text{Circumference [cm]} \times \text{heated length [cm]}}$

*Surface load > 10 W/cm² we recommend a H7 tolerance bore. • Surface load > 20 W/cm² we recommend a press fit. • Maximum surface load depends on heater sheath temperature.

hotrod HHP/G

Casting Cartridge Heater

- Optimal temperature of the material in the goose neck
- Removal stud
- With angle block, tube section and metal sleeving

Specifications	
Sheath material	Stainless steel 1.4541
Diameter mm	6.5 / 8.0 / 10.0 / 12.5 / 16.0 / 20.0
Max. length	On request
Max. sheath temperature	750 °C / 1380 °F
Max. voltage	480 V, UL max. 300 V
Wattage tolerance*	± 10 %
Length tolerance	± 1.5 %, min ± 1 mm
Standard diameter	metric: -0.02 -0.06 mm imperial: ± 0.79 mil [± 0.02 mm]

*tested at environmental temperature

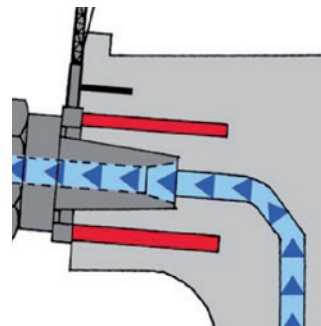

Heating of the goose neck

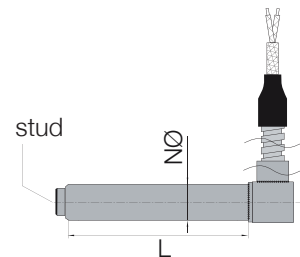

NØ = Nominal diameter · L = Length

Options

- Wattage distribution
- Thermocouple type K
- Various connection options

Stock Range HHP/G

Connection Voltage: 230V, GLS Lead, 1500 mm

Stock ID	Diameter [mm]	Length [mm]	Connection length [mm]	Wattage [W]	Voltage [V]	Goose neck / Nozzle type
HT9906100	10.0	80	1500	250	230	Nozzle DAW 5
HT9906101	12.5	60	1500	200	230	DAW 5
HT9906104	12.5	90	1500	350	230	Nozzle DAW 20
HT9906103	16.0	80	1500	315	230	DAW 10/20
HT9906106	16.0	100	1500	500	230	DAW 40-125
HT9906113	16.0	100	1500	600	230	DAW 40-125
HT9906105	16.0	160	1500	630	230	Nozzle DAW 40-50

hotrod HHP Ø 1/8" (3.1 mm) High Power Cartridge Heater

Specifications	
Max. sheath temperature	700 °C / 1292 °F
Max. sheath surface load	30 W/cm ² / 190 W/inch ²
Min. Length	25.4 mm / 1 inch
Max. Length	150 mm / 5.91 inch
Diameter tolerance	± 0.05 mm / 1.97 mils
Length tolerance	≤ 76.2 mm: ± 2.4 mm / 0.09 inch > 76.2 mm: ± 3 %
UB _a Length	8 mm / 0.31 inch
UB _b Length	6 mm / 0.24 inch
High voltage test	800 V AC
Max. voltage	250 V
Max. current	2.0 A
Connection option	Mounted internally high temperature resistant glass silk insulated Ni-leads, max. Temp. 600 °C / 1112 °F Type 4



UB = Length of the unheated

hotrod HHP Ø 4 mm High Power Cartridge Heater

Specifications	
Max. sheath temperature	275/650 °C / 527/1202 °F
Max. sheath surface load	30 W/cm ² / 190 W/inch ²
Max. Length	350 mm / 13.8 inch
UB _a Length	13 mm / 0.512 inch
UB _b Length	6 mm / 0.236 inch
High voltage test	800 V AC
Max. voltage	250 V
Max. current	2 A
Length tolerance	± 2.5 %, min. ± 1.5 mm / 0.059 inch
Connection type	Type 5a

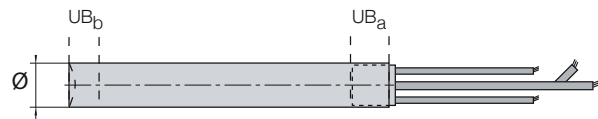

UB = Length of the unheated zone

Options

- Power distribution
- Thermocouple, ungrounded
type J or K (IEC / ANSI color codes),
measuring point at bottom, up to 80 mm heater length
- Diameter tolerances up to -0.02 / -0.04 mm

hotrod HHP Ø 6.0 – 20 mm

High Power Cartridge Heater

Specifications

For metric sizes:	1500 mm
Max. length / Ø-tolerance	Ø-tolerance -0.02 mm -0.06 mm 3000 mm Ø-tolerance ± 0.1 mm

For imperial sizes:	59 inch
Max. length / Ø-tolerance	Ø-tolerance ± 0.79 mil 118 inch Ø-tolerance ± 3.94 mil

Length tolerance	$\pm 1.5\%$, min. ± 1.0 mm / 0.039 inch
------------------	---

UB _a Length	4 to 20 mm / 0.157 to 0.787 inch
------------------------	-------------------------------------

UB _b Length	4 to 9 mm / 0.157 to 0.354 inch
------------------------	------------------------------------

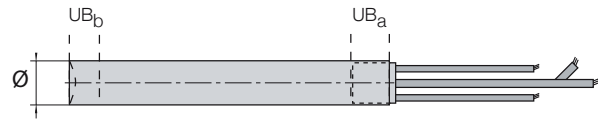

UB = Length of the unheated zone



Options

- Certified according to UL and CSA standards on request
- VDE certified versions
- Wattage distribution
- Thermocouple, grounded or ungrounded type J or K (IEC / ANSI color codes) measuring point at the bottom or in the middle
- Ground lead
- Moisture protection up to IP67
- Various connection options
- Various attachments
- Diameter tolerances up to -0.02 / -0.04 mm

hotrod LHT

Low Power Cartridge Heater

- For lower surface loads with max. 10 W/cm²
- Cost effective heating with a long lifespan

Specifications

Diameter	6.5 / 8.0 / 10.0 / 12.5 / 16.0 / 20.0
Max. sheath temperature	750 °C / 1380 °F
Max. sheath surface load	10 W/cm ² / 64 W/inch ²
Max. length	3000 mm / 118 inch
Length tolerance	$\pm 1.5\%$, min. ± 1.5 mm / 0.059 inch

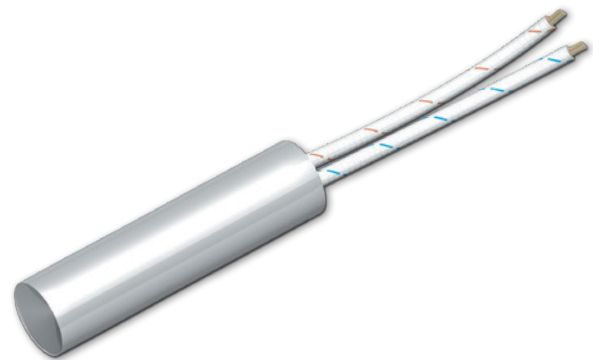

UB = Length of the unheated zone

Options

- Moisture protection
- Various connection options
- In case of extra low voltage, current return via the cartridge sheath is possible
- No high voltage test and no insulation resistance in case of current return via the cartridge sheath (only extra low voltage)
- Connection leads attached to each end of the cartridge possible
- Certified according to UL and CSA standards

hotrod LHT bendable Low Power Cartridge Heater

Specifications	
Diameter	6.5 or 8.0 mm
Sheath material	nickel or stainless steel
Max. sheath temperature	700 °C / 1292 °F
Max. sheath surface load	10 W/cm ² / 64 W/inch ²
Max. length	3000 mm / 118 inch
Length tolerance	± 1.5 %, min. ± 1.5 mm / 0.059 inch
Diameter tolerance	± 0.2 mm / 0.008 inch
Connection	glass silk insulated Ni-leads mounted externally
Min. bending radius	15 mm / 0.59 inch (internal)

Options

- Moisture protection
- Various connection options
- Certified according to UL and CSA standards on request
- Current return over the sheath

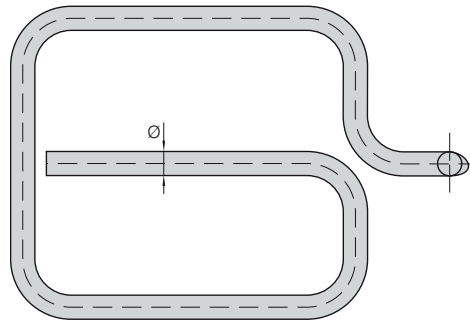
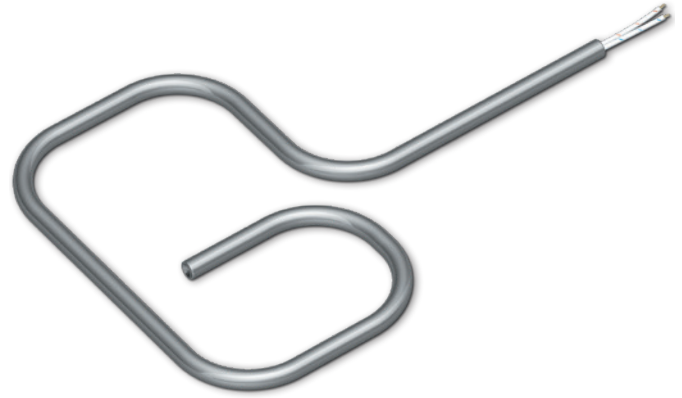

hotrod LHT Knife Cartridge Low Power Cartridge Heater

- Cutting knife for textiles and foils

Specifications	
Diameter	5.0 mm / 0.197 inch 6.5 mm / 0.256 inch
Sheath material	Incoloy
Max. sheath temperature	950 °C / 1742 °F
Diameter tolerance	± 0.1 mm / 0.059 inch
Max. connection voltage	24 V _i with current return via sheath
Connection options	connection pin
Cutting knife	wear-resistant hard metal alloy, pre-formed, ungrinded
Min. bending radius	12.5 mm / 0.049 inch (internal)

Options

- Manufactured straight or bent

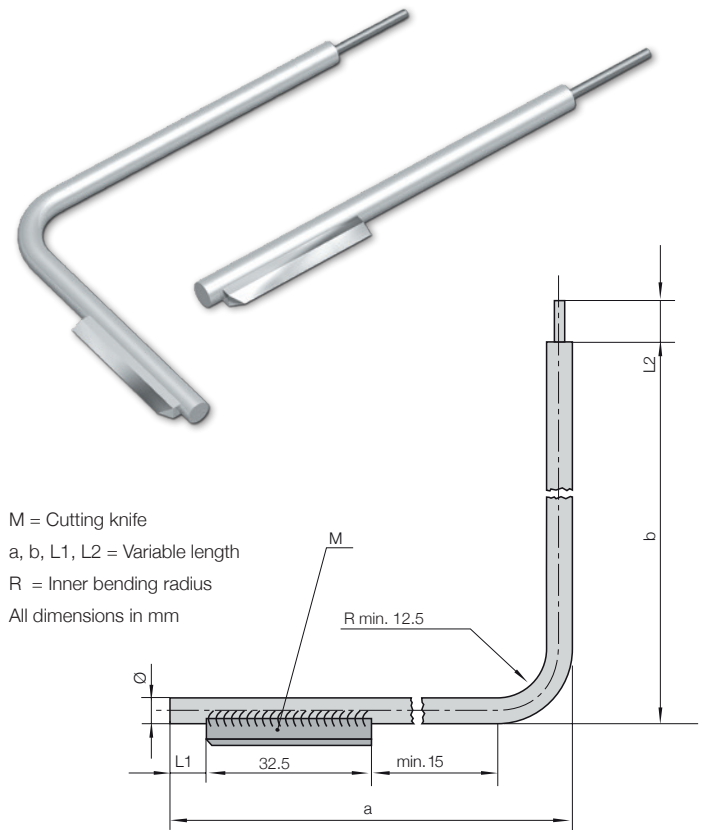

Connection with leads mounted externally

Type 1

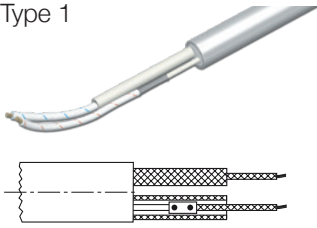

Leads mounted externally,
max. 230 °C / 446 °F siliconized lead,
180 °C / 356 °F

Type 2

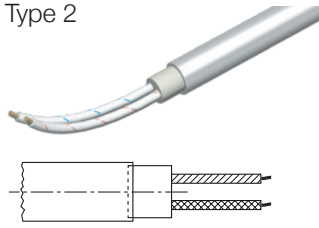

Ceramic head, any leads,
see "Connection leads"

Option for Type 3
(for all)

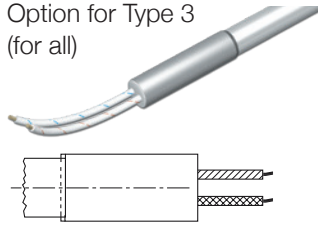

Tube section 40 mm instead of ring
sleeve, e.g. with large lead cross sec-
tions (25 mm tube section on request)

Type 3a

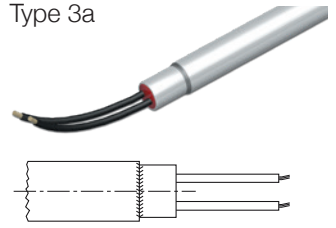

Ring sleeve, silicone leads,
sealed with silicone, moisture protected,
max. 180 °C / 356 °F

Type 3b

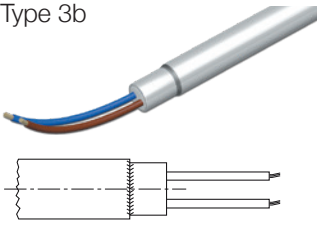

Ring sleeve, PTFE leads,
sealed with epoxy resin, moisture
protected, max. 250 °C / 482 °F

Type 3c

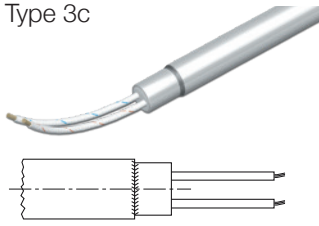

Ring sleeve, GLS leads,
ceramic sealing, max. 320 °C / 608 °F

Type 6

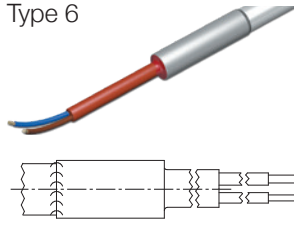

Multi core silicone cable with tube
section 40 mm, sealed with silicone,
moisture protected,
max. 180 °C / 356 °F

Connection with leads mounted internally

Type 4

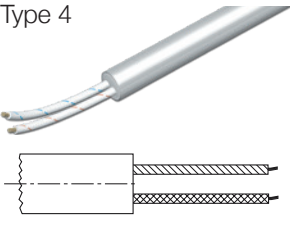

Any Leads, with ceramic closure,
max. 320 °C / 608 °F

Type 5a

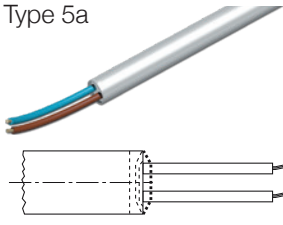

PTFE disc*, PTFE leads,
max. 260 °C / 500 °F

Type 5b

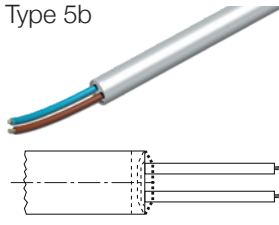

PTFE disc*, IP67 up to 40 W/cm² /
258 W/inch², max. 350 °C / 662 °F
at sheath, 260 °C / 500 °F at leads

Type 5c

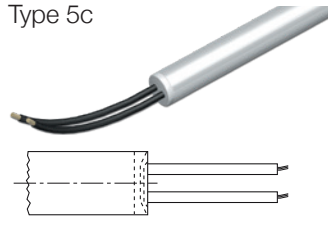

Silicone disc, silicone leads,
max. 180 °C / 356 °F

* PTFE disc can extend length by 1.5 mm.

Connection Leads

Glass silk insulated Ni-leads	max. Temp: 320 °C / 608 °F
Silicone Ni-leads	max. Temp: 180 °C / 356 °F
PTFE insulated Ni-leads (multi-stranded)	max. Temp: 260 °C / 500 °F
High temperature resistant glass silk insulated Ni-leads	max. Temp: 600 °C / 1112 °F
Bare, beaded leads (breakage risk)	max. Temp: 600 °C / 1112 °F

Sleeves

GLS sleeving

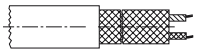

≥ Ø 6.5 mm / ≥ Ø 1/4 inch



Stainless steel sleeving

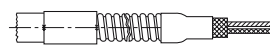

≥ Ø 10 mm / ≥ Ø 3/8 inch



Braided metal sleeving

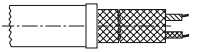

Ø 6.5 mm / Ø 1/4 inch



≥ Ø 12 mm / ≥ Ø 1/2 inch

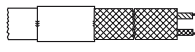

≥ Ø 8 mm



Flexible metal sleeving

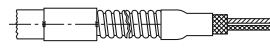

≥ Ø 6.5 mm / ≥ Ø 1/4 inch

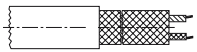

≥ Ø 10 mm / ≥ Ø 3/8 inch

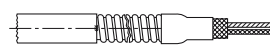

≥ Ø 12 mm / ≥ Ø 1/2 inch



Right Angle Attachments*

Angular block

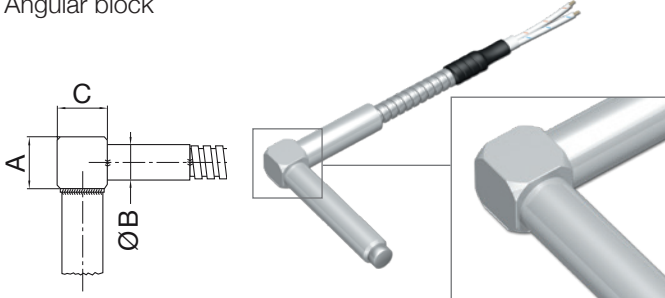

Right angle exit

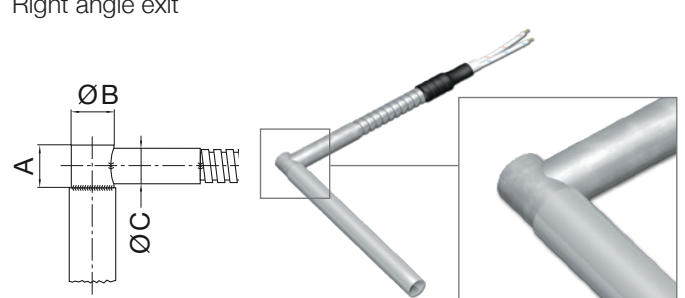

Ø hotrod	A/C [mm]	Ø B [mm]
6.5 mm	10.0	7.5
8.0 mm	10.0	9.0
10.0 mm	14.0	11.0
12.0 mm	14.0	11.0
12.5 mm	14.0	11.0
16.0 mm	18.0	14.0
20.0 mm	25.0	18.0
1/4"	10.0	7.5
3/8"	14.0	11.0
1/2"	14.0	11.0
5/8"	18.0	14.0
3/4"	25.0	18.0

Ø hotrod	A [mm]	B [mm]	C [mm]
8.0 mm	10.0	7.5	7.5
10.0 mm	11.0	9.0	9.0
12.0 mm	13.0	12.0	11.0
12.5 mm	13.0	12.0	11.0
16.0 mm	16.0	15.0	14.0
20.0 mm	18.0	19.5	18.0
3/8"	11.0	9.0	9.0
1/2"	13.0	12.0	11.0
5/8"	16.0	15.0	14.0
3/4"	18.0	18.5	18.0

* Remarks

- All attachments are mounted at the unheated zone of the heater
- Please state immersion depth with order

Flange and Threaded Nipple Attachments*

Threaded nipple

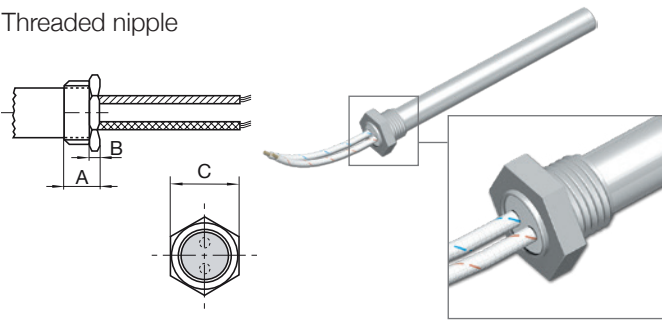

Ø hotrod	A [mm]	B [mm]	C [mm]	Thread
6.5 mm	10.0	4.0	12	M10 x 1.0 mm
8.0 mm	10.0	4.0	14	M12 x 1.0 mm
10.0 mm	12.0	4.0	17	M14 x 1.5 mm
12.0 mm	12.0	4.0	16	M16 x 1.5 mm
12.5 mm	12.0	4.0	19	M16 x 1.5 mm
16.0 mm	12.0	4.0	24	M20 x 1.5 mm
20.0 mm	14.0	4.0	27	M26 x 1.5 mm
1/4"	10.0	4.0	12	G 1/8"
3/8"	12.0	4.0	17	G 1/4"
1/2"	12.0	4.0	19	G 3/8"
5/8"	12.0	4.0	24	G 1/2"

Threaded nipple with removal aid

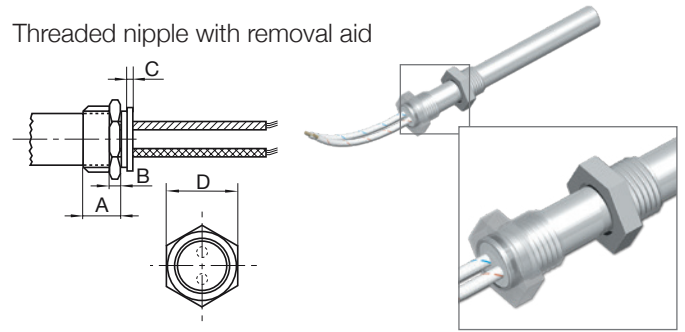

Ø hotrod	A [mm]	B [mm]	C [mm]	D [mm]	Thread
6.5 mm	10.0	4.0	2.5	12	M10 x 1.0 mm
8.0 mm	10.0	4.0	2.5	14	M12 x 1.0 mm
10.0 mm	12.0	4.0	2.5	17	M14 x 1.5 mm
12.0 mm	12.0	4.0	2.5	19	M16 x 1.5 mm
12.5 mm	12.0	4.0	2.5	19	M16 x 1.5 mm
16.0 mm	12.0	4.0	2.5	24	M20 x 1.5 mm
20.0 mm	14.0	4.0	2.5	27	M26 x 1.5 mm
1/4"	10.0	4.0	2.5	12	G 1/8"
3/8"	12.0	4.0	2.5	17	G 1/4"
1/2"	12.0	4.0	2.5	19	G 3/8"
5/8"	12.0	4.0	2.5	24	G 1/2"

Flange

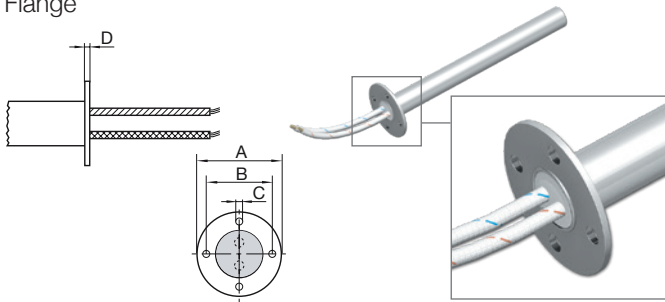

Ø hotrod	A [mm]	B [mm]	C [mm]	D [mm]
6.5 mm	18.0	13.0	2.2	1.0
8.0 mm	18.0	13.0	2.2	1.2
10.0 mm	27.0	20.0	3.2	1.2
12.0 mm	27.0	20.0	3.2	1.2
12.5 mm	27.0	20.0	3.2	1.5
16.0 mm	33.0	25.6	3.2	1.5
20.0 mm	33.0	25.6	3.2	1.5
1/4"	18.0	13.0	2.2	1.0
3/8"	27.0	20.0	3.2	1.2
1/2"	27.0	20.0	3.2	1.2
5/8"	33.0	25.6	3.2	1.5

Mounting clamp

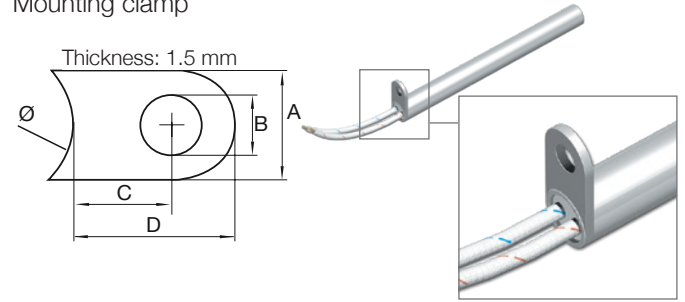

Ø hotrod [mm]	A [mm]	B [mm]	C [mm]	D [mm]
10.0	10.0	5.0	10.0	14.0
12.0	8.0	4.5	4.0	8.0
12.5	12.2	5.5	7.95	14.7
16.0	12.2	6.9	10.9	17.7
20.0	12.2	5.5	12.5	20.0

Stock Range

Stock Range HHP Ø 6.5 mm, 230 V

Stock ID	Length [mm]	Wattage [W]	Tool Preparation	Connection Type	Thermocouple
HT5210404	40	100	Press fit (DIN EN ISO 286-1)	4, GLS 1 m	Fe-CuNi Typ J
HT4010404	40	100	Press fit (DIN EN ISO 286-1)	4, GLS 1 m	
HT4010405	40	125	Press fit (DIN EN ISO 286-1)	4, GLS 1 m	
HT4010410	40	160	Press fit (DIN EN ISO 286-1)	4, GLS 1 m	
HT4010411	40	175	Press fit (DIN EN ISO 286-1)	4, GLS 1 m	
HT4010415	40	200	Press fit (DIN EN ISO 286-1)	4, GLS 1 m	
HT4010504	50	100	H7-tolerance bore	4, GLS 1 m	
HT4010510	50	160	Press fit (DIN EN ISO 286-1)	4, GLS 1 m	
HT5210515	50	200	Press fit (DIN EN ISO 286-1)	4, GLS 1 m	Fe-CuNi Typ J
HT4010515	50	200	Press fit (DIN EN ISO 286-1)	4, GLS 1 m	
HT4010517	50	250	Press fit (DIN EN ISO 286-1)	4, GLS 1 m	
HT4010605	60	125	H7-tolerance bore	4, GLS 1 m	
HT5210615	60	200	Press fit (DIN EN ISO 286-1)	4, GLS 1 m	Fe-CuNi Typ J
HT4010615	60	200	Press fit (DIN EN ISO 286-1)	4, GLS 1 m	
HT5210617	60	250	Press fit (DIN EN ISO 286-1)	4, GLS 1 m	Fe-CuNi Typ J
HT4010617	60	250	Press fit (DIN EN ISO 286-1)	4, GLS 1 m	
HT4010805	80	125	H7-tolerance bore	4, GLS 1 m	
HT4010815	80	200	H7-tolerance bore	4, GLS 1 m	
HT4010822	80	315	Press fit (DIN EN ISO 286-1)	4, GLS 1 m	
HT4011010	100	160	H7-tolerance bore	4, GLS 1 m	
HT5211023	100	350	Press fit (DIN EN ISO 286-1)	4, GLS 1 m	Fe-CuNi Typ J
HT4011023	100	350	Press fit (DIN EN ISO 286-1)	4, GLS 1 m	
HT4011316	130	220	H7-tolerance bore	4, GLS 1 m	
HT4011323	130	350	H7-tolerance bore	4, GLS 1 m	

For components subjected to surface loads greater than 20W/cm², the use of an interference fit is necessary, which can be achieved by individual adjustment of the cartridge or a split borehole (half shells with interference fit).

Final part ID may be different to stock ID

Stock Range HHP Ø 8.0 mm, 230 V

Stock ID	Length [mm]	Wattage [W]	Tool Preparation	Connection Type	Thermocouple
HT4020404	40	100	Press fit (DIN EN ISO 286-1)	4, GLS 1 m	
HT4020410	40	160	Press fit (DIN EN ISO 286-1)	4, GLS 1 m	
HT4020415	40	200	Press fit (DIN EN ISO 286-1)	4, GLS 1 m	
HT4020417	40	250	Press fit (DIN EN ISO 286-1)	4, GLS 1 m	
HT4020515	50	200	Press fit (DIN EN ISO 286-1)	4, GLS 1 m	
HT5220517	50	250	Press fit (DIN EN ISO 286-1)	4, GLS 1 m	Fe-CuNi Typ J
HT4020517	50	250	Press fit (DIN EN ISO 286-1)	4, GLS 1 m	
HT4020522	50	315	Press fit (DIN EN ISO 286-1)	4, GLS 1 m	
HT4020605	60	125	H7-tolerance bore	4, GLS 1 m	
HT4020615	60	200	Press fit (DIN EN ISO 286-1)	4, GLS 1 m	
HT4020617	60	250	Press fit (DIN EN ISO 286-1)	4, GLS 1 m	
HT5220617	60	250	Press fit (DIN EN ISO 286-1)	4, GLS 1 m	Fe-CuNi Typ J
HT4020815	80	200	H7-tolerance bore	4, GLS 1 m	
HT4020822	80	315	Press fit (DIN EN ISO 286-1)	4, GLS 1 m	
HT4020826	80	400	Press fit (DIN EN ISO 286-1)	4, GLS 1 m	
HT4021015	100	200	H7-tolerance bore	4, GLS 1 m	
HT4021017	100	250	H7-tolerance bore	4, GLS 1 m	
HT5221022	100	315	Press fit (DIN EN ISO 286-1)	4, GLS 1 m	Fe-CuNi Typ J
HT4021022	100	315	H7-tolerance bore	4, GLS 1 m	
HT4021026	100	400	Press fit (DIN EN ISO 286-1)	4, GLS 1 m	
HT4021317	130	250	H7-tolerance bore	4, GLS 1 m	
HT4021322	130	315	H7-tolerance bore	4, GLS 1 m	
HT5221326	130	400	Press fit (DIN EN ISO 286-1)	4, GLS 1 m	Fe-CuNi Typ J
HT4021326	130	400	H7-tolerance bore	4, GLS 1 m	
HT4021615	160	200	H7-tolerance bore	4, GLS 1 m	

For components subjected to surface loads greater than 20W/cm², the use of an interference fit is necessary, which can be achieved by individual adjustment of the cartridge or a split borehole (half shells with interference fit).

Final part ID may be different to stock ID

Stock Range HHP Ø 10.0 mm, 230 V

Stock ID	Length [mm]	Wattage [W]	Tool Preparation	Connection Type	Thermocouple
HT5230415	40	200	Press fit (DIN EN ISO 286-1)	4, GLS 1 m	Fe-CuNi Typ J
HT4030415	40	200	Press fit (DIN EN ISO 286-1)	4, GLS 1 m	
HT4030422	40	315	Press fit (DIN EN ISO 286-1)	4, GLS 1 m	
HT4030515	50	200	Press fit (DIN EN ISO 286-1)	4, GLS 1 m	
HT5230517	50	250	Press fit (DIN EN ISO 286-1)	4, GLS 1 m	Fe-CuNi Typ J
HT4030517	50	250	Press fit (DIN EN ISO 286-1)	4, GLS 1 m	
HT4030526	50	400	Press fit (DIN EN ISO 286-1)	4, GLS 1 m	
HT5230617	60	250	Press fit (DIN EN ISO 286-1)	4, GLS 1 m	Fe-CuNi Typ J
HT4030617	60	250	Press fit (DIN EN ISO 286-1)	4, GLS 1 m	
HT4030622	60	315	Press fit (DIN EN ISO 286-1)	4, GLS 1 m	
HT4030626	60	400	Press fit (DIN EN ISO 286-1)	4, GLS 1 m	
HT4030630	60	500	Press fit (DIN EN ISO 286-1)	4, GLS 1 m	
HT4030810	80	160	H7-tolerance bore	4, GLS 1 m	
HT5230817	80	250	Press fit (DIN EN ISO 286-1)	4, GLS 1 m	Fe-CuNi Typ J
HT4030817	80	250	H7-tolerance bore	4, GLS 1 m	
HT4030822	80	315	H7-tolerance bore	4, GLS 1 m	
HT4030826	80	400	Press fit (DIN EN ISO 286-1)	4, GLS 1 m	
HT4030830	80	500	Press fit (DIN EN ISO 286-1)	4, GLS 1 m	
HT4030835	80	630	Press fit (DIN EN ISO 286-1)	4, GLS 1 m	
HT4031016	100	220	H7-tolerance bore	4, GLS 1 m	
HT4031017	100	250	H7-tolerance bore	4, GLS 1 m	
HT4031022	100	315	H7-tolerance bore	4, GLS 1 m	
HT5231023	100	350	Press fit (DIN EN ISO 286-1)	4, GLS 1 m	Fe-CuNi Typ J
HT4031023	100	350	H7-tolerance bore	4, GLS 1 m	
HT4031026	100	400	H7-tolerance bore	4, GLS 1 m	
HT4031030	100	500	Press fit (DIN EN ISO 286-1)	4, GLS 1 m	
HT4031035	100	630	Press fit (DIN EN ISO 286-1)	4, GLS 1 m	
HT4031044	100	850	Press fit (DIN EN ISO 286-1)	4, GLS 1 m	
HT4031326	130	400	H7-tolerance bore	4, GLS 1 m	
HT4031330	130	500	H7-tolerance bore	4, GLS 1 m	
HT4031335	130	630	Press fit (DIN EN ISO 286-1)	4, GLS 1 m	
HT4031343	130	800	Press fit (DIN EN ISO 286-1)	4, GLS 1 m	
HT5231626	160	400	H7-tolerance bore	4, GLS 1 m	Fe-CuNi Typ J
HT4031626	160	400	H7-tolerance bore	4, GLS 1 m	
HT5231635	160	630	Press fit (DIN EN ISO 286-1)	4, GLS 1 m	Fe-CuNi Typ J
HT4031635	160	630	H7-tolerance bore	4, GLS 1 m	
HT4032026	200	400	H7-tolerance bore	4, GLS 1 m	
HT4032035	200	630	H7-tolerance bore	4, GLS 1 m	

For components subjected to surface loads greater than 20W/cm², the use of an interference fit is necessary, which can be achieved by individual adjustment of the cartridge or a split borehole (half shells with interference fit).

Final part ID may be different to stock ID

Stock Range HHP Ø 12.5 mm, 230 V

Stock ID	Length [mm]	Wattage [W]	Tool Preparation	Connection Type	Thermocouple
HT4050417	40	250	Press fit (DIN EN ISO 286-1)	4, GLS 1 m	
HT4050615	60	200	H7-tolerance bore	4, GLS 1 m	
HT4050622	60	315	Press fit (DIN EN ISO 286-1)	4, GLS 1 m	
HT4050822	80	315	H7-tolerance bore	4, GLS 1 m	
HT4050830	80	500	H7-tolerance bore	4, GLS 1 m	
HT4050843	80	800	Press fit (DIN EN ISO 286-1)	4, GLS 1 m	
HT4051026	100	400	H7-tolerance bore	4, GLS 1 m	
HT4051035	100	630	Press fit (DIN EN ISO 286-1)	4, GLS 1 m	
HT4051326	130	400	H7-tolerance bore	4, GLS 1 m	
HT4051335	130	630	H7-tolerance bore	4, GLS 1 m	
HT4051343	130	800	Press fit (DIN EN ISO 286-1)	4, GLS 1 m	
HT4051352	130	1250	Press fit (DIN EN ISO 286-1)	4, GLS 1 m	
HT4051630	160	500	H7-tolerance bore	4, GLS 1 m	
HT4051643	160	800	H7-tolerance bore	4, GLS 1 m	
HT4051850	180	1000	H7-tolerance bore	4, GLS 1 m	
HT4052043	200	800	H7-tolerance bore	4, GLS 1 m	
HT4052047	200	900	H7-tolerance bore	4, GLS 1 m	
HT4052543	250	800	H7-tolerance bore	4, GLS 1 m	
HT4052547	250	900	H7-tolerance bore	4, GLS 1 m	

For components subjected to surface loads greater than 20W/cm², the use of an interference fit is necessary, which can be achieved by individual adjustment of the cartridge or a split borehole (half shells with interference fit).

Final part ID may be different to stock ID

Stock Range HHP Ø 16.0 mm, 230 V

Stock ID	Length [mm]	Wattage [W]	Tool Preparation	Connection Type	Thermocouple
HT4060417	40	250	Press fit (DIN EN ISO 286-1)	4, GLS 1 m	
HT4060615	60	200	H7-tolerance bore	4, GLS 1 m	
HT4060622	60	315	H7-tolerance bore	4, GLS 1 m	
HT4060626	60	400	Press fit (DIN EN ISO 286-1)	4, GLS 1 m	
HT4060830	80	500	H7-tolerance bore	4, GLS 1 m	
HT4060843	80	800	Press fit (DIN EN ISO 286-1)	4, GLS 1 m	
HT4061026	100	400	H7-tolerance bore	4, GLS 1 m	
HT4061030	100	500	H7-tolerance bore	4, GLS 1 m	
HT4061035	100	630	H7-tolerance bore	4, GLS 1 m	
HT4061043	100	800	Press fit (DIN EN ISO 286-1)	4, GLS 1 m	
HT4061050	100	1000	Press fit (DIN EN ISO 286-1)	4, GLS 1 m	
HT4061330	130	500	H7-tolerance bore	4, GLS 1 m	
HT4061335	130	630	H7-tolerance bore	4, GLS 1 m	
HT4061343	130	800	H7-tolerance bore	4, GLS 1 m	
HT4061643	160	800	H7-tolerance bore	4, GLS 1 m	
HT4061650	160	1000	H7-tolerance bore	4, GLS 1 m	
HT4061852	180	1250	H7-tolerance bore	4, GLS 1 m	
HT4062050	200	1000	H7-tolerance bore	4, GLS 1 m	
HT4062052	200	1250	H7-tolerance bore	4, GLS 1 m	
HT4062061	200	2000	Press fit (DIN EN ISO 286-1)	4, GLS 1 m	
HT4062555	250	1600	H7-tolerance bore	4, GLS 1 m	
HT4063050	300	1000	H7-tolerance bore	4, GLS 1 m	
HT4063052	300	1250	H7-tolerance bore	4, GLS 1 m	
HT4063054	300	1500	H7-tolerance bore	4, GLS 1 m	
HT4063056	300	1800	H7-tolerance bore	4, GLS 1 m	

For components subjected to surface loads greater than 20W/cm², the use of an interference fit is necessary, which can be achieved by individual adjustment of the cartridge or a split borehole (half shells with interference fit).

Final part ID may be different to stock ID

Stock Range HHP Ø 20.0 mm, 230 V

Stock ID	Length [mm]	Wattage [W]	Tool Preparation	Connection Type	Thermocouple
HT4070622	60	315	H7-tolerance bore	4, GLS 1 m	
HT4070843	80	800	Press fit (DIN EN ISO 286-1)	4, GLS 1 m	
HT4071050	100	1000	Press fit (DIN EN ISO 286-1)	4, GLS 1 m	
HT4071650	160	1000	H7-tolerance bore	4, GLS 1 m	
HT4072055	200	1600	H7-tolerance bore	4, GLS 1 m	
HT4072561	250	2000	H7-tolerance bore	4, GLS 1 m	
HT4073062	300	2200	H7-tolerance bore	4, GLS 1 m	

For components subjected to surface loads greater than 20W/cm², the use of an interference fit is necessary, which can be achieved by individual adjustment of the cartridge or a split borehole (half shells with interference fit).

Final part ID may be different to stock ID

Stock Range HHP Ø 1/4" (Ø 6.3 mm), 230 V

Stock ID	Length [inch]	Wattage [W]	Tool Preparation	Connection Type	Thermocouple
HT4110305	1 1/2	125	Press fit (DIN EN ISO 286-1)	4, GLS 1 m	
HT4110315	1 1/2	200	Press fit (DIN EN ISO 286-1)	4, GLS 1 m	
HT4110505	2	125	Press fit (DIN EN ISO 286-1)	4, GLS 1 m	
HT5310515	2	200	Press fit (DIN EN ISO 286-1)	4, GLS 1 m	Fe-CuNi Typ J
HT5310617	2 1/2	250	Press fit (DIN EN ISO 286-1)	4, GLS 1 m	Fe-CuNi Typ J
HT4110617	2 1/2	250	Press fit (DIN EN ISO 286-1)	4, GLS 1 m	

Stock Range HHP Ø 3/8" (Ø 9.46 mm), 230 V

Stock ID	Length [inch]	Wattage [W]	Tool Preparation	Connection Type	Thermocouple
HT4130517	2	250	Press fit (DIN EN ISO 286-1)	4, GLS 1 m	
HT4130726	3	400	Press fit (DIN EN ISO 286-1)	4, GLS 1 m	
HT4131230	5	500	H7-tolerance bore	4, GLS 1 m	

Stock Range HHP Ø 1/2" (Ø 12.61 mm), 230 V

Stock ID	Length [inch]	Wattage [W]	Tool Preparation	Connection Type	Thermocouple
HT4150726	3	400	H7-tolerance bore	4, GLS 1 m	
HT4151030	4	500	H7-tolerance bore	4, GLS 1 m	
HT4151240	5	750	H7-tolerance bore	4, GLS 1 m	

For components subjected to surface loads greater than 20W/cm², the use of an interference fit is necessary, which can be achieved by individual adjustment of the cartridge or a split borehole (half shells with interference fit).

Final part ID may be different to stock ID



hotset

Hotset GmbH
Hueckstraße 16
58511 Lüdenscheid
Germany

Phone +49 / 23 51 / 43 02-0
Fax +49 / 23 51 / 43 02-25

www.hotset.com